

NOTE:

1. CURBSTOP BOX AND METER ARE PROVIDED BY SWDC AND INSTALLED BY CONTRACTOR

2. A 10 GAUGE TRACER WIRE SHALL BE CONNECTED TO CURB STOP VALVE & RAN ALONG SIDE THE SERVICE LATERAL TO THE METER.

3. LATERAL SHALL BE BLUE POLY (200psi) BED AND FILL SHALL BE FINES WITH WATER TAPE 3' ABOVE THE PIPE.

5. REDUCED PRESSURE BFP MAY DISCHARGE WATER AND MUST BE PLUMBED TO DRAIN. AIR GAP MUST BE MAINTAINED.

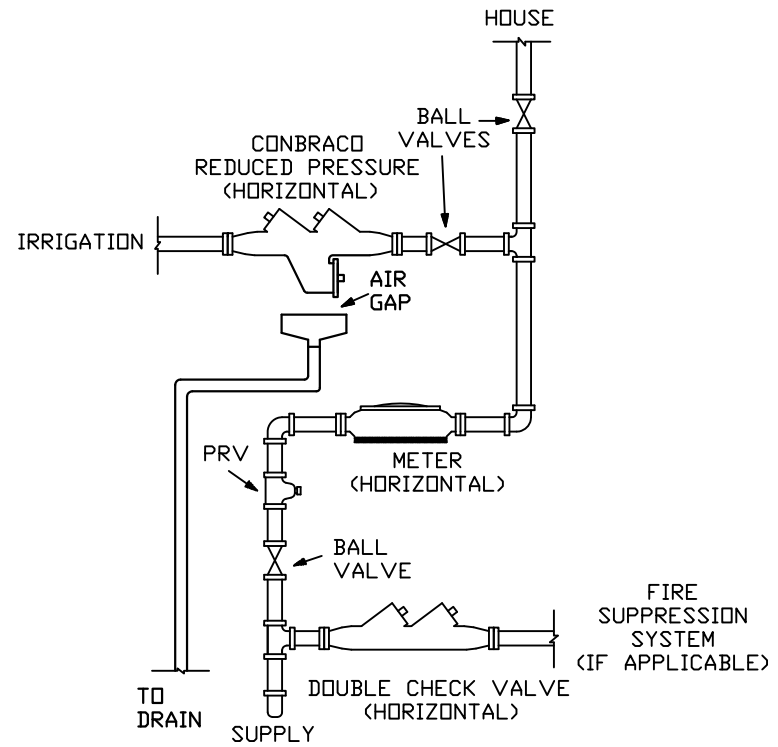
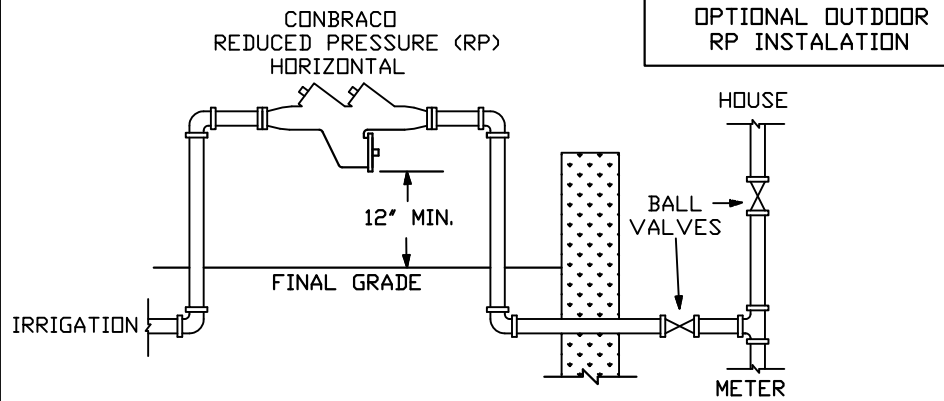
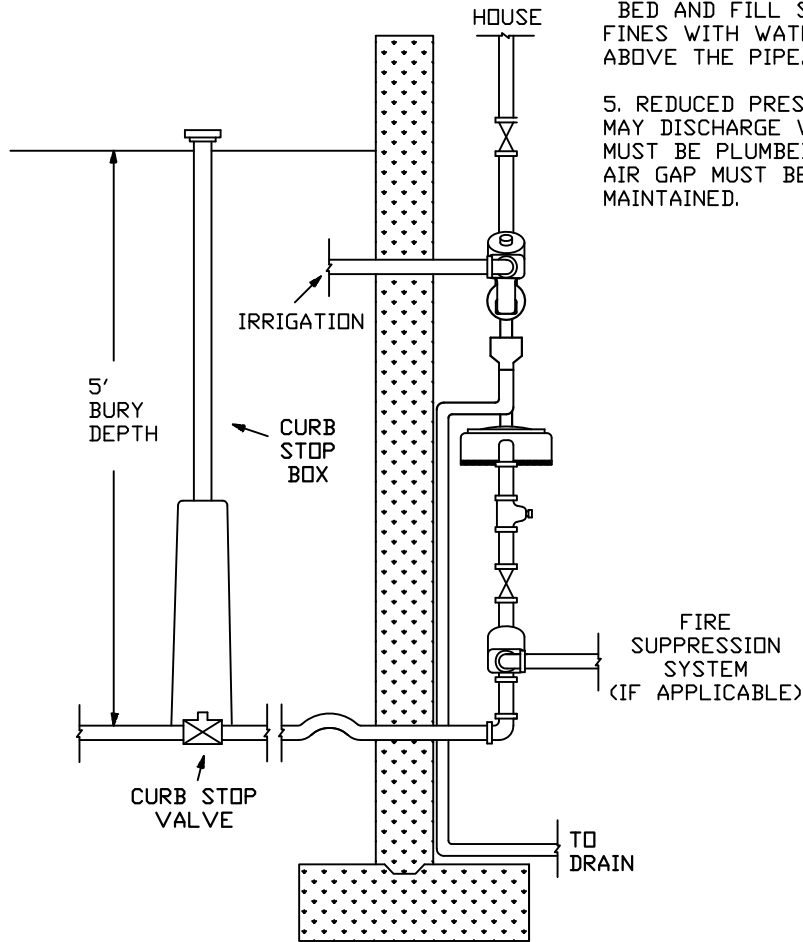

REV.	DATE	BY	DESCRIPTION
2	3/8/06	MF	UPDATED TO RP BACKFLOW
1	4/18/05	MF	

SUMMIT WATER DISTRIBUTION CO.

3/4" TO 2" SERVICE CONNECTION